

Seat Belt and Komfort Latch[®] Gen2 Instructions and Usage Guide

Using the Komfort Latch Gen2

The Komfort Latch is an optional feature. If you decide to use it, the process of relieving seat belt tension is simplified.

1. Adjust the seat to its proper driving position.
2. Latch your seat belt.
3. If available, adjust the Seat Belt Height Adjuster to a comfortable driving position, as shown in Figure 1.

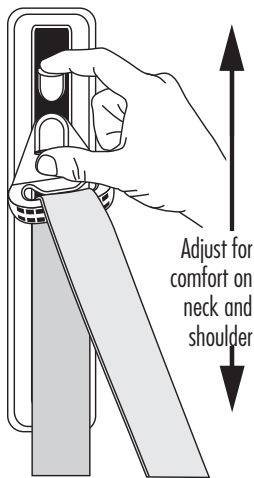
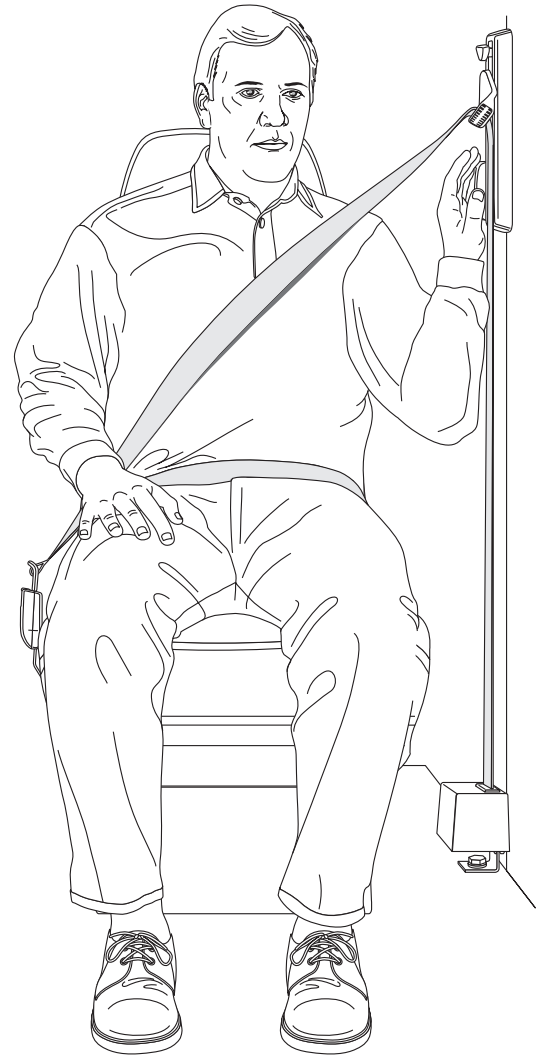

Figure 1

Shoulder Belt Web Guide

Pinch the height adjuster's top and bottom levers together to move the shoulder loop to a comfortable height. The shoulder belt should be centered and lying flat across the chest - between your neck and the edge of your shoulder.

Move the shoulder loop until it clicks into a locked position.



To Set the Komfort Latch Gen2:

1. While seated in a comfortable driving position, with the seat belt on and adjusted, push the "ON" button to engage the Komfort Latch (Figure 2).
2. After the Komfort Latch button is engaged, lean forward in the seat until you hear a "click."

This sets the slack in the seat belt to approximately one inch. When you move forward, for example to check your side mirrors, the Komfort Latch allows approximately five to seven inches of web to be released without disengaging.

CAUTION: Be sure that you don't introduce more than one inch of slack when using the Komfort Latch. Using the seat belt with too much slack can reduce its effectiveness during a crash.

To Release the Komfort Latch Gen2:

Always disengage the Komfort Latch when removing the seat belt. This allows the seat belt to fully retract.

1. There are two ways to disengage the Komfort Latch:
 - a. Unbuckle and tug on the upper torso portion of the seat belt.
 - b. Press the "OFF" button on the Komfort Latch (Figure 2) and unbuckle the seat belt.

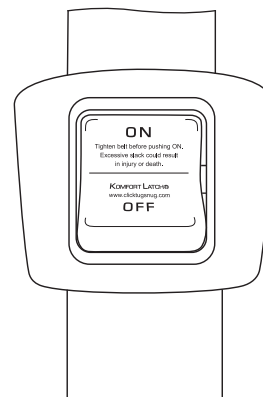

Komfort Latch

Figure 2

Seat Belt and Komfort Latch[®] Gen2 Installation Instructions

To Install with Shoulder Loop Web Guide:

1. Be sure the seat belt is not twisted between the retractor and shoulder loop.
2. Assemble hardware as shown in Figure 1. Some applications require an optional metal spacer to move the Komfort Latch and shoulder loop away from the vehicle cab trim. This metal spacer should only be used when specified by the vehicle manufacturer.
3. The Komfort Latch must be installed vertically aligned with seat belt from retractor. See Figure 2. When installed, the shoulder loop and Komfort Latch must rotate freely. Both must return to the horizontal position when the belt is retracted as shown in Figure 2. The approximate position of the shoulder loop when the seat belt is in use is shown in Figure 3.
4. Tighten bolt to 35 - 50 ft-lbs torque.

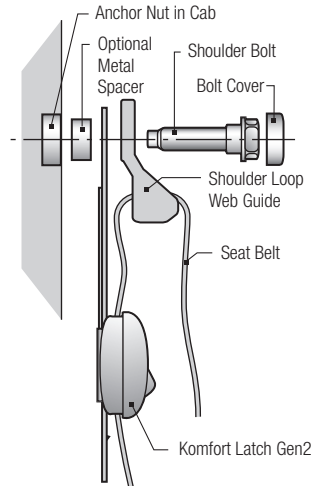
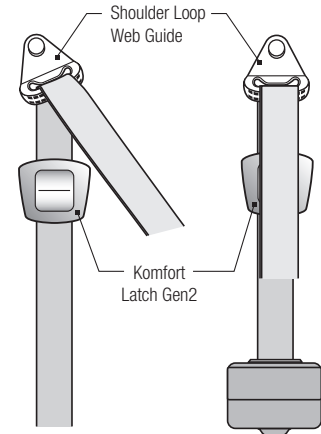
**Figure 1****Figure 2****Figure 3**

To Install with Seat Belt Height Adjuster:

1. Be sure the seat belt is not twisted between the retractor and the height adjuster.
2. Align seat belt height adjuster bolts with 2 threaded mounting holes in vehicle B-pillar or mounting surface. See Figure 4.
3. Locate bolt heads inside channel through trim brushes.
4. Torque against B-pillar or mounting surface by alternately tightening top and bottom bolt until fully torqued to 35 - 50 ft-lbs.

IMPORTANT:

Verify proper position and installation of seat belt height adjuster by moving shoulder loop web guide through full range of adjustment. See Figure 5. Top bolt must not interfere with adjustment.

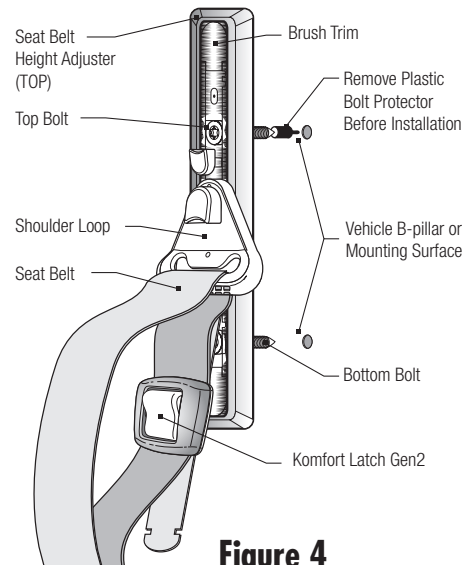
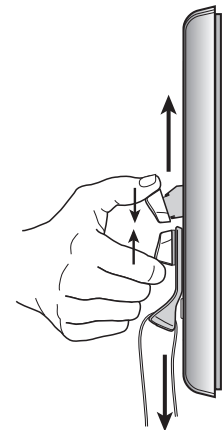
**Figure 4****Figure 5**

Important Features to Check

1. Be sure the seat belt is not twisted between the retractor and shoulder loop web guide.
2. Be sure shoulder loop web guide rotates freely.
3. Once retractor and shoulder loop web guide have been installed, the system must extract and retract seat belt webbing freely.
4. Be sure all bolts have been properly torqued to 35 - 50 ft-lbs.
5. Be sure Komfort Latch can slide freely up and down and does not interfere with vehicle trim.